

## WIZARD 1000 Features/Technical Data

**Display** 2-, 3- or 4-axes 5.7" transmissive LCD display

### Common Functions

- Multiple program names with numerous steps
- Multiple display views - DRO1 & DRO2
- Job clock
- Feed rate display
- Advanced skew compensation
- Multiple language supports
- Absolute/incremental
- Near-zero warning
- Help function
- 16 tool offsets / diameter
- Preset and zero reset
- 4 function calculator / Trig calculator
- Instant inch/mm conversion
- Position-Trac™

### Milling Specific Functions

- Bolthole pattern calculations with graphics (full and partial circles/linear patterns)
- Centerline calculation enables you to establish workpiece zero and midpoints
- Edge finder/touch probe input

### Turning Specific Functions

- Lock axis feature - used in conjunction with tool offsetting, lets you establish tool offsets with the tool under load, resulting in reduced tool deflection.
- Instant radius / diameter conversion
- Taper calculator

### Error Compensation

Linear and non-linear compensation up to +/-9,999 ppm

### Construction

Die-cast metal

### Data Interface

RS-232-C/V.24 serial port

### Electrical Requirements

Voltage of 100-240 Vac  
Power of 30 VA max  
Frequency of 50/60 Hz (+/-3Hz)

### Operating Temperature

0 degrees to 45 degrees C  
(32 degrees to 113 degrees F)

### Storage Temperature

-20 degrees to 70 degrees C  
(-22 degrees to 158 degrees F)

### Weight

4.85 lbs.

### Options

CSS-I/O (Constant surface speed), Electronic Edgefinder, Multiple scale coupling box, DRO handle kit, and DRO panel mount kit.

### Certifications

ISO-9001:2001, UL, CSA, CE

**ANILAM**  
THE CLEAR CHOICE.

P.N. 73000-237 Rev. 4/07



ANILAM IS AN  
ISO 9001  
CERTIFIED  
MANUFACTURER  
CE



Made in USA



## Precision Glass Scales.

With more than one million scales in use today, ANILAM precision glass scales withstand the elements of contamination found in even the harshest machine shop environments.

As a result, our precision glass scales resist changes in size, shape or density due to temperature and humidity variations. This stability provides exceptional accuracy down to  $\pm 1.5\mu\text{m}$  (.00006"), resulting in tighter workpiece tolerances. ANILAM precision glass scales are available in travel lengths from 1"-773" and in resolutions from  $0.5\mu\text{m}$  (.00002") to  $5\mu\text{m}$  (.0002").

### ANILAM USA

One Precision Way, Jamestown, NY 14701  
Tel: 800.344.2311 Fax: 716.661.1884

Web: [www.anilam.com](http://www.anilam.com) / E-mail: [anilaminc@anilam.com](mailto:anilaminc@anilam.com)

### ANILAM USA - West Coast

16312 Garfield Avenue, Unit B, Paramount, CA 90723  
Tel: 562.408.3334 Fax: 562.634.5459

Web: [www.anilam.com](http://www.anilam.com) / E-mail: [anilaml@anilam.com](mailto:anilaml@anilam.com)

### Acu-Rite Companies China

Room 1986, Tower B, City Center of Shanghai  
No. 100 Zunyi Lu Road, Chang Ning District  
200051 Shanghai P.R.C

Tel: 011.86.21.62370398 Fax: 011.86.21.62372320  
E-mail: [china@anilam.com](mailto:china@anilam.com)

### ANILAM GmbH Germany

Fraunhoferstrasse 1, D-83301, Traunreut, Germany  
Tel: 011.49.8669.856110 Fax: 011.49.8669.850930

Web: [www.anilam.de](http://www.anilam.de) / E-mail: [info@anilam.de](mailto:info@anilam.de)

### ANILAM s.r.l Italy

Strada Borgaretto, 38, 10043 Orbassano, Torino, Italy  
Tel: 011.39.011.900.2606 Fax: 011.39.011.900.2466

Web: [www.anilam.it](http://www.anilam.it) / E-mail: [info@anilam.it](mailto:info@anilam.it)

### ANILAM TW Taiwan

No. 246 Chau-Fu Road, Taichung City 407, Taiwan, ROC  
Tel: 011.886.4.225.87222 Fax: 011.886.4.225.87260

E-mail: [anilamt@anilam.com](mailto:anilamt@anilam.com)

### ACI (UK) Limited

16 Plover Close, Interchange Park, Newport Pagnell  
Buckinghamshire, MK16 9PS United Kingdom  
Tel: 011.44.0.1908.514.500 Fax: 011.44.0.1908.610.111

Web: [www.aciuk.co.uk](http://www.aciuk.co.uk) / E-mail: [sales@aciuk.co.uk](mailto:sales@aciuk.co.uk)

# WIZARD 1000

## Programmable LCD Digital Readouts

### The Clear Choice.

The ANILAM WIZARD 1000 features exclusive LCD display screen technology and versatile software to accommodate milling or turning applications – all with the same bright, crystal clear readout. Plus, a content-sensitive help function assists you right on screen.

The ANILAM WIZARD 1000 is a fully programmable readout and can store programs like an electronic notepad. With the programming function, you are able to create, edit and execute programs from the program mode.

The ANILAM WIZARD 1000 provides the capability to create a library of program names, each independently labeled. Each program can hold multiple steps, resulting in the ability to generate a large number of program files.

The ANILAM WIZARD 1000 contains a variety of programming features such as tool step, datum step, preset step, circle pattern step (mill only), linear pattern step (mill only), and incline and arc milling steps (mill only).

### WIZARD 1000 for Milling Applications.

Available for up to 4-axis large milling machine tool applications.

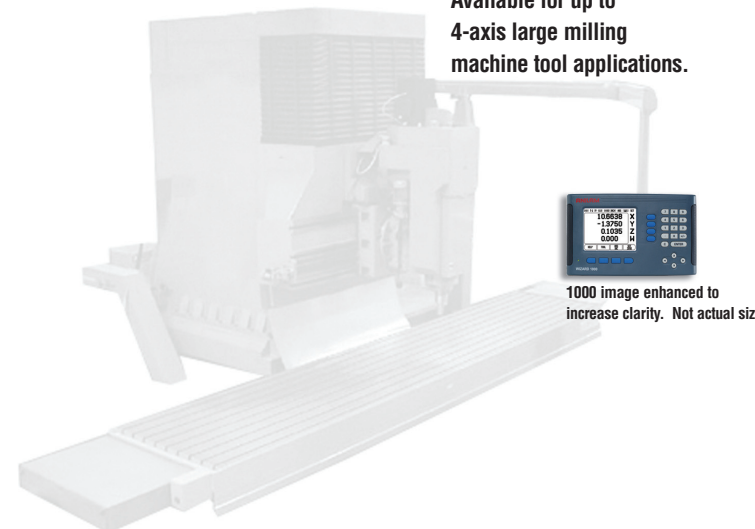

1000 image enhanced to increase clarity. Not actual size



### WIZARD 1000 for Turning Applications.

The ultimate in efficiency and productivity for turning applications utilizing state-of-the-art features.



1000 image enhanced to increase clarity. Not actual size

**ANILAM**